

---

# Table of Contents

## E65 NAVIGATION SYSTEM

<b>Subject</b>	<b>Page</b>
Introduction. . . . .	3
System Overview. . . . .	4
Components	
Navigation Computer. . . . .	5
GPS Antenna. . . . .	6
Speed Signal. . . . .	6
MOST. . . . .	6
RGB Lines. . . . .	6
Principle of Operation	
Navigation Display. . . . .	7
New Functions. . . . .	8
Review Questions. . . . .	10

---

## **E65 NAVIGATION SYSTEM**

**Model: E65 - 745i**

**Production Date: 11/2001 - Start of Production**

### **Objective:**

After completing this model you should be able to:

- Recognize the new features available in the E65 navigation system over the previous E38.

---

## Introduction

The navigation computer of the E65 is the control unit that provides navigation, telematics and Online services (planned).

In terms of the functionality, the navigation computer corresponds to the Mk-3 navigation computer introduced for model year 2001. A number of additional functions however, have been integrated.

- New, larger screen (8.8 inches) with an 8:3 size ratio.
- Simultaneous map and arrow presentation modes.
- Map or arrow presentation in assistance window always possible (simultaneously with radio menu, etc.).
- New-route calculation is faster when the driver has to deviate from the planned route.
- Improved map presentation graphics.
- Faster on-screen map builds.
- "Avoiding toll road" as a new routing criteria.
- Multiple destinations can be grouped in a destinations list and picked up one after the other.
- Route information arrows, distance and name of the next street shown in the instrument cluster.
- Extended voice output ("... follow the I95 interstate").
- Direct destination home (also by voice command).
- Avoiding individual roads or entire roadway sections.
- Help text explanations for individual menu items.

Like all information and communication systems, the control unit is connected to the MOST bus.

# System Overview

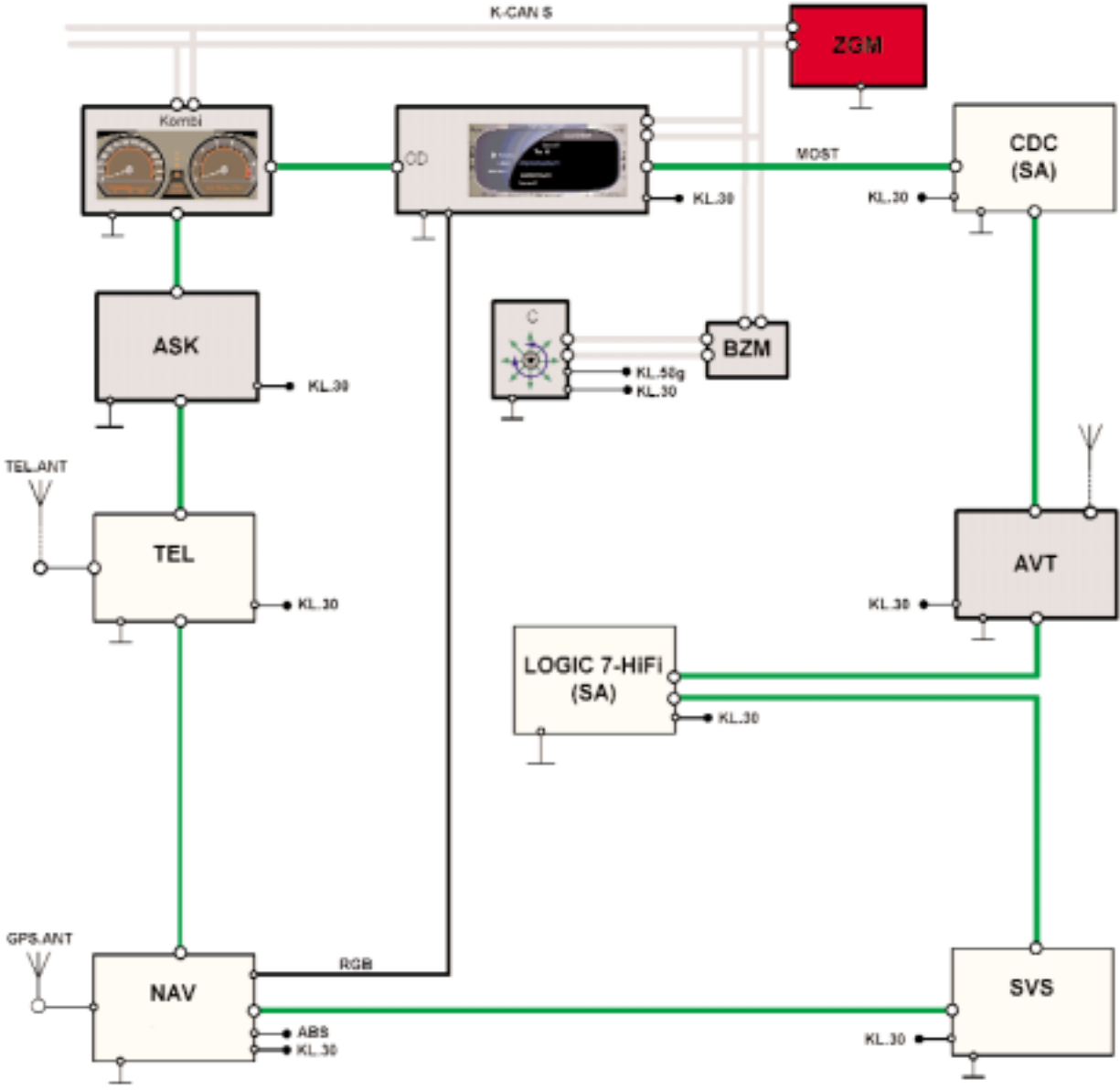

kt-8963

---

## Components

### Navigation Computer (NAV. 01)

The navigation computer is located in the left rear corner of the luggage compartment.

Similar to the Mk-3 computer, the E65 NAV. 01 contains:

- CD drive.
- Hardware for navigation, telematics and online services function.
- Transceiver for interface with the MOST network. (Transceiver contains two nodes)
- Gyro sensor.
- GPS receiver.
- Output for RGB (graphics interface)
- Cooling fan for unit.

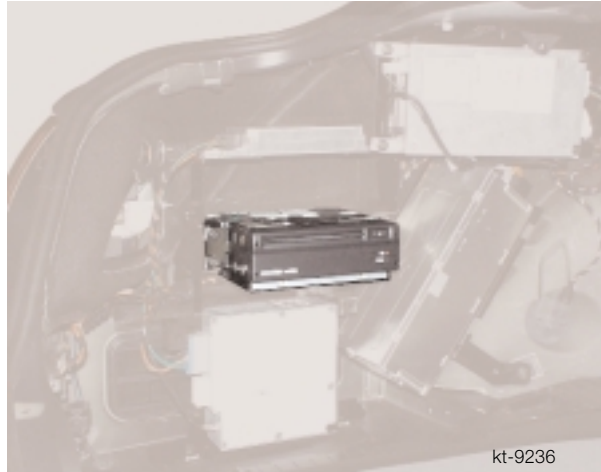

Building maps on the Control Display is now considerably faster than before. This improvement was achieved by means of modifications to the hardware.

The connection to the MOST bus is by a standardized MOST transceiver. The MOST transceiver incorporates two interfaces (nodes).

Each MOST telegram is divided into 3 parts.

- Control data
- Asynchronous data (e.g. navigation system, arrow presentation)
- Synchronous data (e.g. audio, video signals)

A node can analyze only two signals at a time, this is the reason why two nodes are necessary for the navigation computer. In the Control Display self-test, both nodes are shown as control units but only one node can be displayed as a recognized control unit. The second node is always displayed as "wait" (normally control unit not recognized).

## GPS Antenna

The antenna for the navigation system is incorporated into the shark-fin antenna that is mounted on the roof.

This antenna contains a dual band antenna for the telephone as well as the GPS antenna.

1. GPS antenna
2. GPS connector

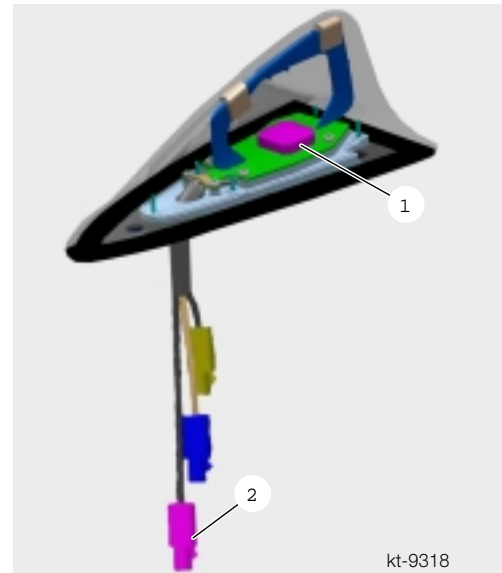

## Speed Signal

The road speed signal is provided directly by the DSC. The signal is processed from the left front wheel sensor.

## MOST

The navigation computer is part of the MOST network. Like all the control units in the MOST system, the navigation computer is woken up by light signals on the MOST bus, this means that the nav. computer has to be in permanent operation.

Standby current consumption is less than 0.02 mA.

The data for the route arrows displayed in the instrument cluster and in the Control Display is carried on the MOST bus.

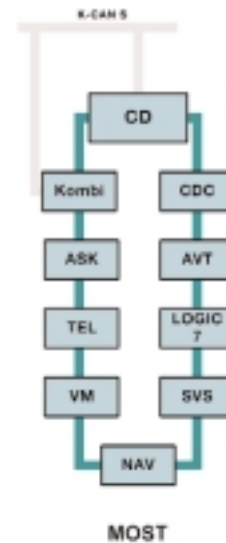

## RGB Lines

The navigation computer sends the signal for map display directly to the Control Display along separate RGB lines.

## Principle of Operation

### Navigation Display

The information is presented in the Control Display and the instrument cluster. The display window in the Control Display has been re-sized to a width-to-height ratio of 8:3 (previous wide-screen BM 16:9).

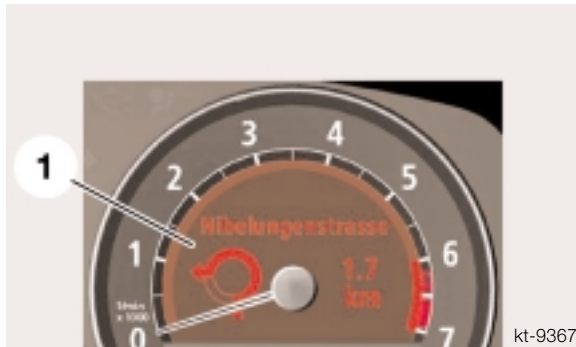

When Route Guidance (with arrow display selected) is active, the navigation display also appears automatically in the instrument cluster.

Display of the information in the instrument cluster cannot be deactivated while the route guidance function is active.

The display of navigation information in the Control Display can be deactivated by selecting some other function.

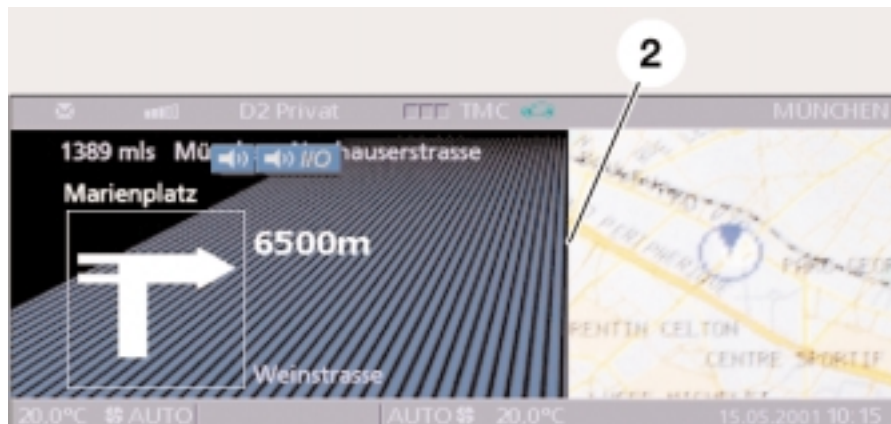

1. Arrow display in Kombi.

2. Arrow display in control area and map in assistance screen of Control Display.

kt-9357

Map or arrow display in assistance window is always possible (simultaneously with radio menu, BC, etc.)

1. Entertainment menu in control area

2. Map in assistance screen.



kt-9359

## New Functions

### New Route

New-route calculation is faster when the driver has to deviate from the planned route. Instead of recalculating the entire route when the driver deviates from the planned route, the computer re-calculates only a section of the route before issuing the next instruction, this saves time.

### Avoiding Toll Road

This is a new selection that has been added to the route-selection menu along with the previous: fastest route, main use of highways, least use of highways, etc.).

### Selection of Destination from Stored Memory

Multiple destinations are stored in a destinations list. To select the current desired route from memory, the destination must be selected and placed as number 1.



1. Destination list
2. Destinations 1 and 2.

kt-9360

### Display of Navigation Data in the Instrument Cluster

Route information, distance and the name of the next street can now be shown in the instrument cluster providing the driver with navigation data without having to look away from the road.

1. Street name
2. Distance until next turn.
3. Route arrow





## Extended Voice Instructions

The voice instructions have a greater vocabulary thanks to the faster processor and greater system memory of the navigation computer. (e.g. “Continue straight ahead following I95”, instead of, “follow the main road”).

## Direct Home Function

Selecting home is easier by storing it permanently in memory and selecting it from a “home” icon in the address book menu or using the Speech Processing System to access it.



1. Home icon, used to select, enter and change home address.
2. Button for deleting destinations in destinations list.

kt-9364

## Avoiding Sections of a Road or Complete Roads

From the New Route menu individual roads or complete roadways can be barred and the navigation computer will develop a new route avoiding those specific roads. This is especially useful to avoid long term construction sites or roads that are commonly congested with traffic.

1. Avoid section.
2. Avoid route



kt-9363

---

## Review Questions

1. Where is the antenna for the navigation system located? \_\_\_\_\_  
\_\_\_\_\_  
\_\_\_\_\_
  
2. How many “nodes” are integrated in to the navigation computer? Why does it have that many? How can this affect troubleshooting a MOST bus problem?  
\_\_\_\_\_  
\_\_\_\_\_  
\_\_\_\_\_  
\_\_\_\_\_  
\_\_\_\_\_  
\_\_\_\_\_  
\_\_\_\_\_
  
3. How does the navigation computer send display images to the Control Display and the instrument cluster? \_\_\_\_\_  
\_\_\_\_\_  
\_\_\_\_\_  
\_\_\_\_\_  
\_\_\_\_\_  
\_\_\_\_\_  
\_\_\_\_\_